

ALS01 SYSTEM

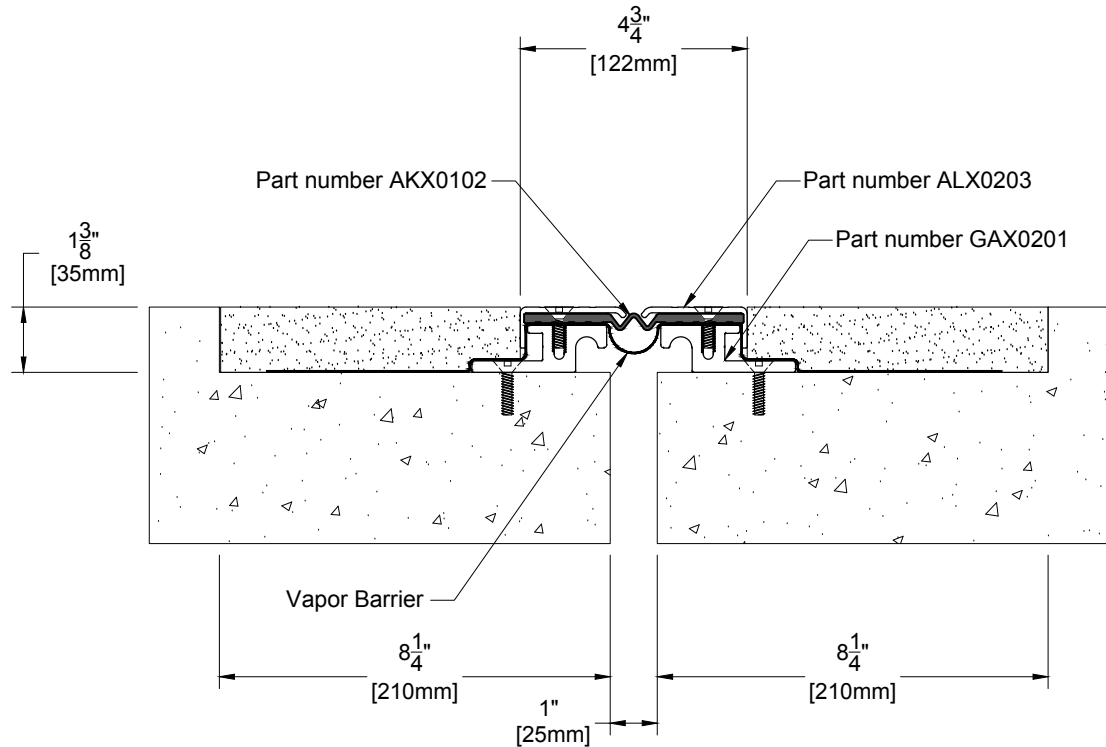

TECHNICAL DATA	IMPERIAL (inc)	METRIC (mm)
Joint Width	1"	25
Movement ± (Horizontal)	1/2"	13
Movement ± (Vertical)	1/2"	13
Load	5 Tons	
Date:	Scale: NTS	
Rev:	Drawn by :	

APPLICATION:
Expansion Joint Cover for Floor to Floor Condition (Heavy Duty)



PROSPEC SPECIALTIES INC.
3601 HIGHWAY 7, SUITE 400
MARKHAM ON L3R 0M3, CANADA.
TEL: (888) - 749 - 8456,
FAX: (888) - 749 - 8455
Email: info@prospecspecialties.com
Web: prospecspecialties.com

Disclaimer: As Prospec Specialties' Policy is one of continual technical progress for the improvement of the company's services to its customers, the company reserves the right to modify the Designs of its products without notice

ALS02 SYSTEM

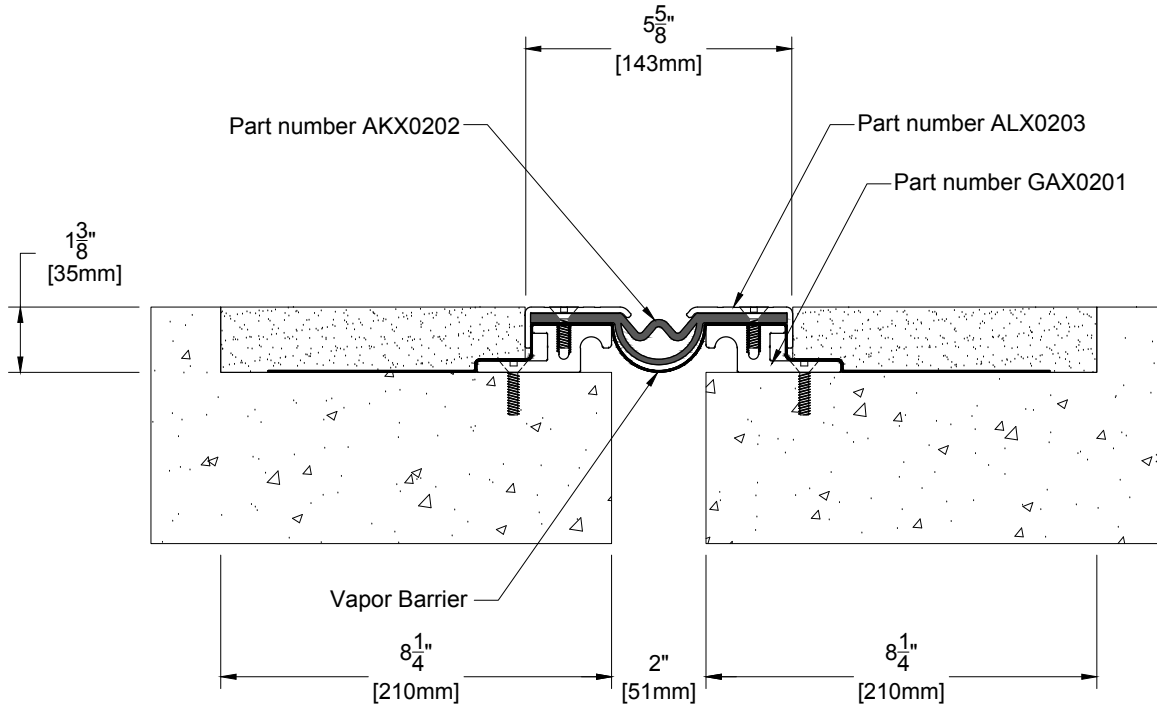

TECHNICAL DATA	IMPERIAL (inc)	METRIC (mm)
Joint Width	2"	51
Movement ± (Horizontal)	1"	25
Movement ± (Vertical)	1"	25
Load	5 Tons	
Date:	Scale: NTS	
Rev:	Drawn by :	

APPLICATION:
Expansion Joint Cover for Floor to Floor
Condition (Heavy Duty)



PROSPEC SPECIALTIES INC.
3601 HIGHWAY 7, SUITE 400
MARKHAM ON L3R 0M3, CANADA.
TEL: (888) - 749 - 8456,
FAX: (888) - 749 - 8455
Email: info@prospecspecialties.com
Web: prospecspecialties.com

Disclaimer: As Prospec Specialties' Policy is one of continual technical progress for the improvement of the company's services to its customers, the company reserves the right to modify the Designs of its products without notice

ALS03 SYSTEM

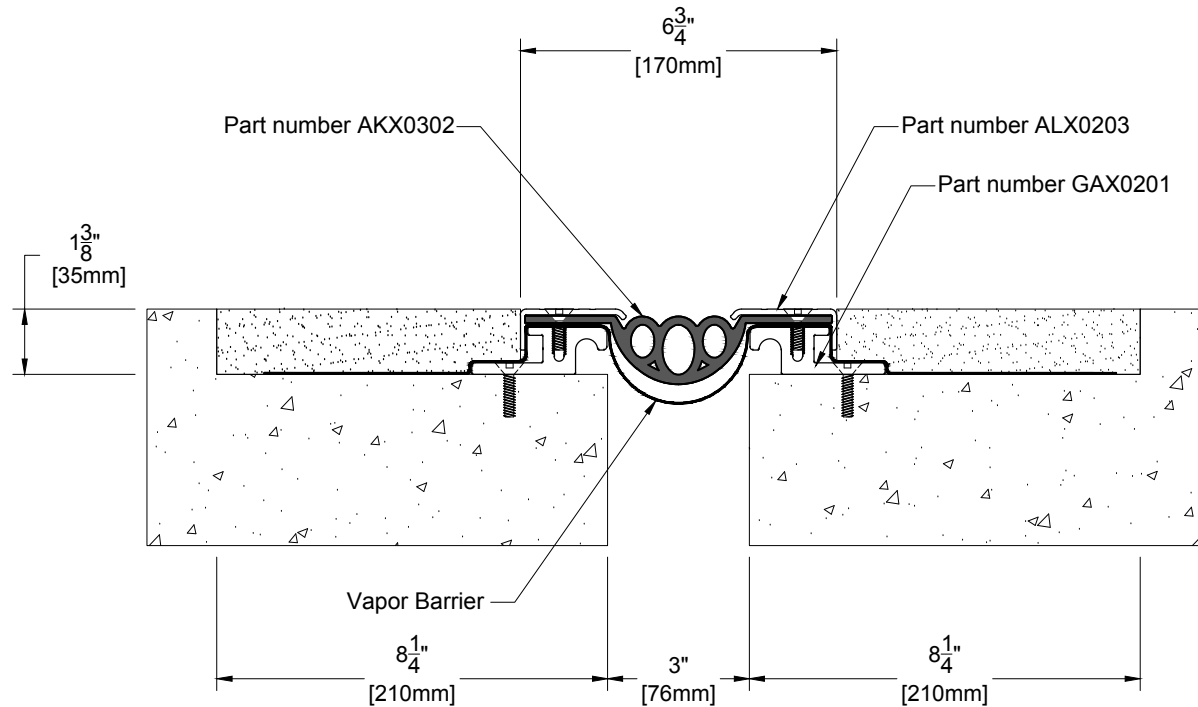

TECHNICAL DATA	IMPERIAL (inc)	METRIC (mm)
Joint Width	3"	76
Movement ± (Horizontal)	1-1/2"	38
Movement ± (Vertical)	1-1/2"	38
Load	5 Tons	
Date:	Scale: NTS	
Rev:	Drawn by :	

APPLICATION:
Expansion Joint Cover for Floor to Floor
Condition (Heavy Duty)



PROSPEC SPECIALTIES INC.
3601 HIGHWAY 7, SUITE 400
MARKHAM ON L3R 0M3, CANADA.
TEL: (888) - 749 - 8456,
FAX: (888) - 749 - 8455
Email: info@prospecspecialties.com
Web: prospecspecialties.com

Disclaimer: As Prospec Specialties' Policy is one of continual technical progress for the improvement of the company's services to its customers, the company reserves the right to modify the Designs of its products without notice

ALS04 SYSTEM

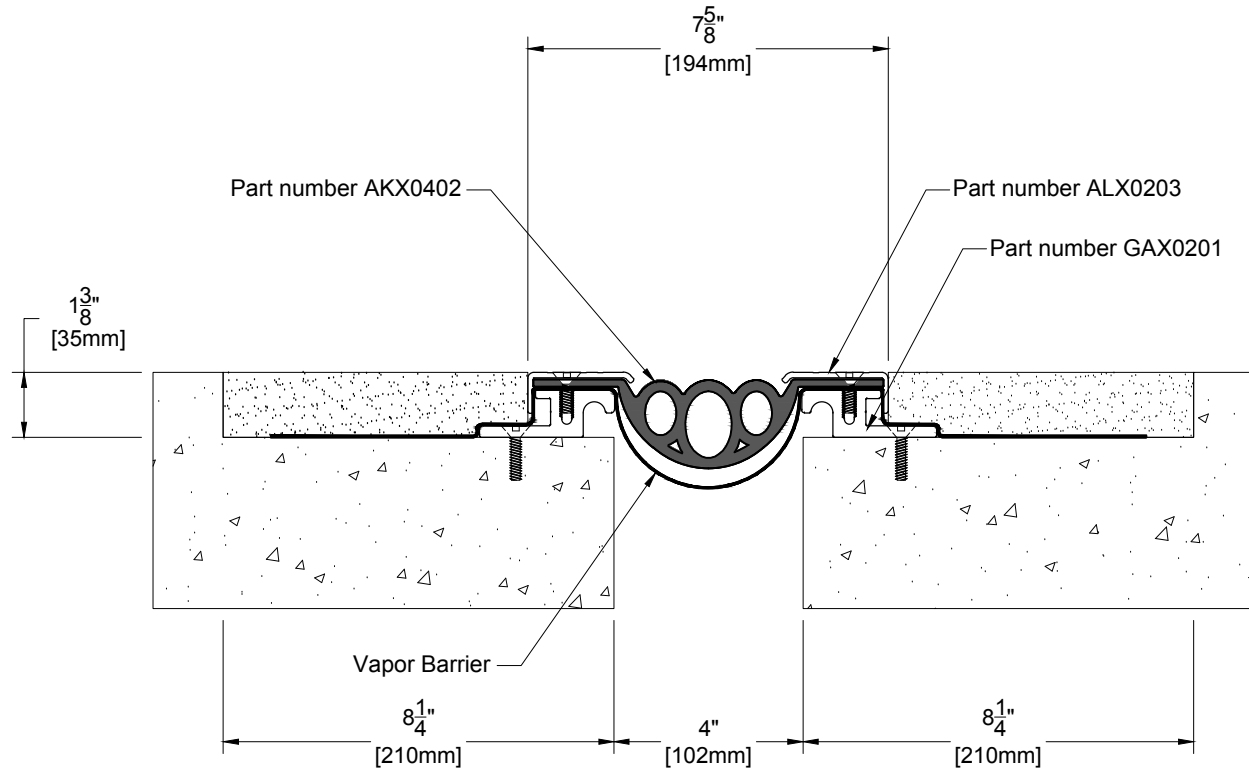

TECHNICAL DATA	IMPERIAL (inc)	METRIC (mm)
Joint Width	4"	102
Movement ± (Horizontal)	2"	51
Movement ± (Vertical)	2"	51
Load	5 Tons	
Date:	Scale: NTS	
Rev:	Drawn by :	

APPLICATION:
Expansion Joint Cover for Floor to Floor
Condition (Heavy Duty)



PROSPEC SPECIALTIES INC.
3601 HIGHWAY 7, SUITE 400
MARKHAM ON L3R 0M3, CANADA.
TEL: (888) - 749 - 8456,
FAX: (888) - 749 - 8455
Email: info@prospecspecialties.com
Web: prospecspecialties.com

Disclaimer: As Prospec Specialties' Policy is one of continual technical progress for the improvement of the company's services to its customers, the company reserves the right to modify the Designs of its products without notice.