

CAC01 SYSTEM

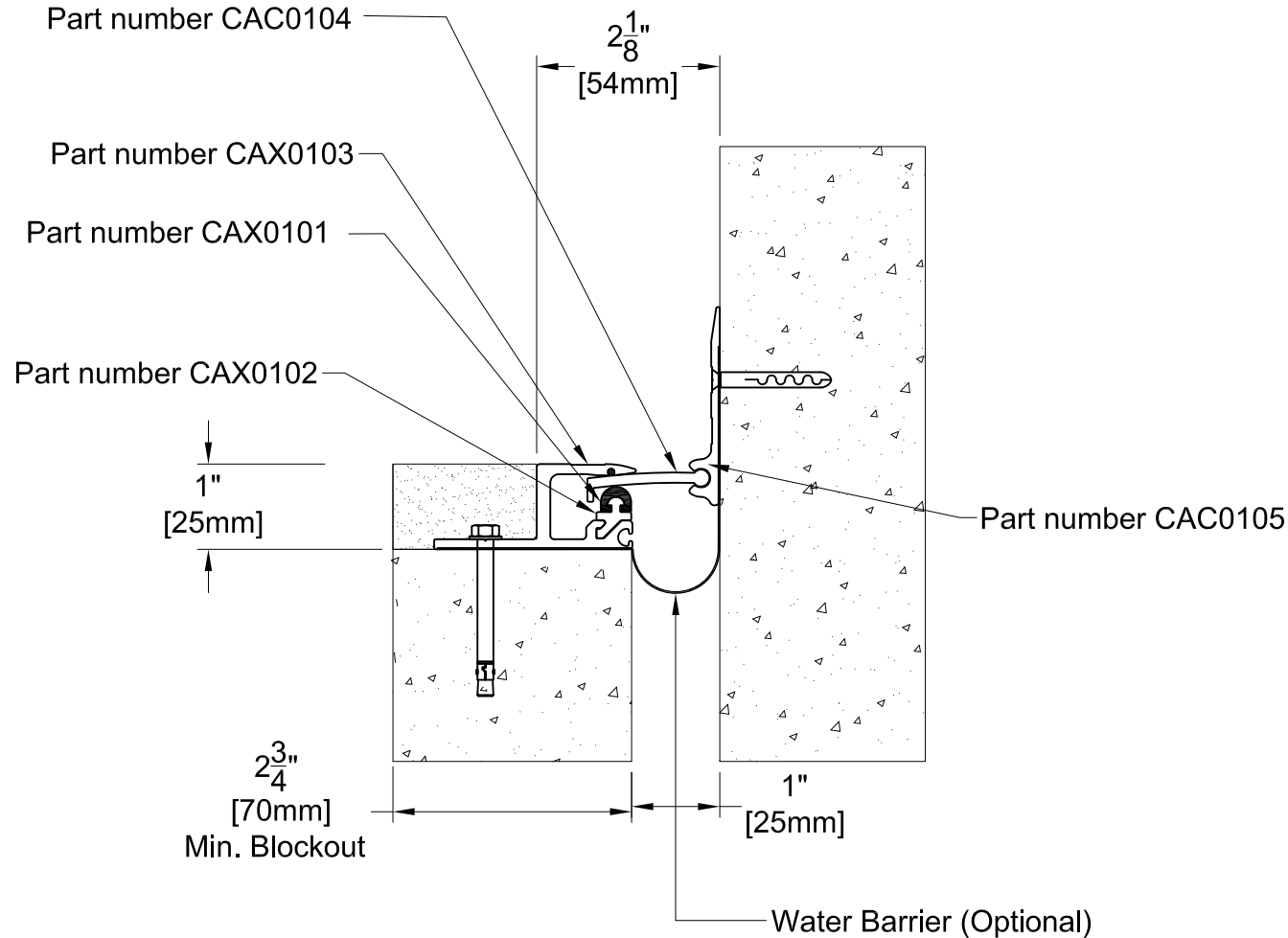

TECHNICAL DATA	IMPERIAL (Inc)	METRIC (mm)
Joint Width	1"	25
Movement ± (Horizontal)	1/4"	6
Movement ± (Vertical)	1/8"	3
Load	4 (Tons)	
Date: Jan., 2012	Scale: NTS	
Rev:	Drawn by :	

APPLICATION:
EXPANSION JOINT COVER FOR FLOOR TO WALL



PROSPEC SPECIALTIES INC.
3601 HIGHWAY 7, SUITE 400
MARKHAM ON L3R 0M3, CANADA.
TEL: (888) - 749 - 8456,
FAX: (888) - 749 - 8455
Email: info@prospecspecialties.com
Web: prospecspecialties.com

CAC02 SYSTEM

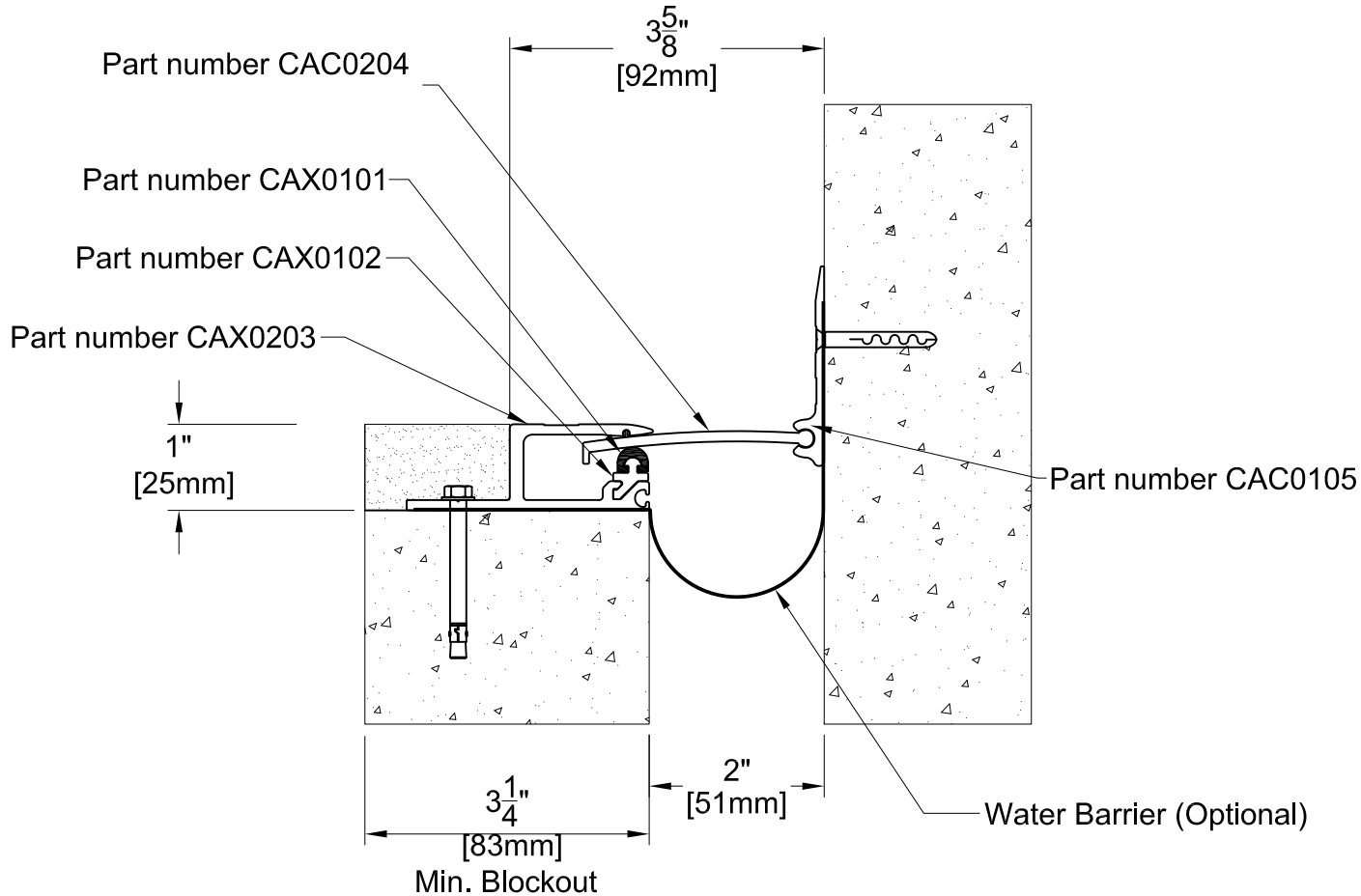

TECHNICAL DATA	IMPERIAL (inc)	METRIC (mm)
Joint Width	2"	50
Movement ± (Horizontal)	1/2"	13
Movement ± (Vertical)	1/4"	6
Load	3 (Tons)	
Date: Jan., 2012	Scale: NTS	
Rev:	Drawn by :	

APPLICATION:
EXPANSION JOINT COVER FOR FLOOR TO WALL



PROSPEC SPECIALTIES INC.
3601 HIGHWAY 7, SUITE 400
MARKHAM ON L3R 0M3, CANADA.
TEL: (888) - 749 - 8456,
FAX: (888) - 749 - 8455
Email: info@prospecspecialties.com
Web: prospecspecialties.com

CAC03 SYSTEM

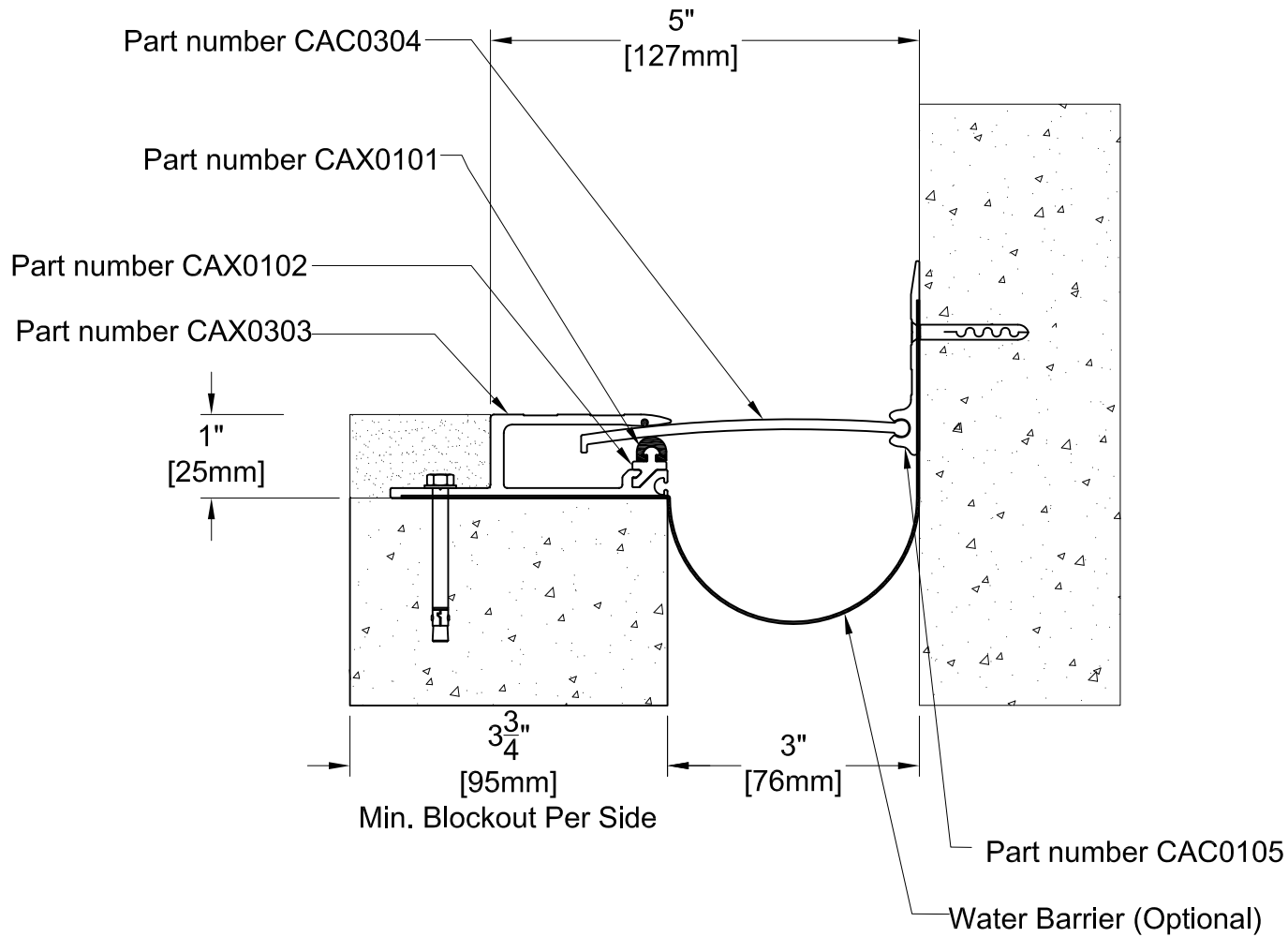

TECHNICAL DATA	IMPERIAL (inc)	METRIC (mm)
Joint Width	3"	75
Movement ± (Horizontal)	3/4"	19
Movement ± (Vertical)	3/8"	10
Load	2 (Tons)	
Date: Jan., 2012	Scale: NTS	
Rev:	Drawn by :	

APPLICATION:
EXPANSION JOINT COVER FOR FLOOR TO WALL



PROSPEC SPECIALTIES INC.
3601 HIGHWAY 7, SUITE 400
MARKHAM ON L3R 0M3, CANADA.
TEL: (888) - 749 - 8456,
FAX: (888) - 749 - 8455
Email: info@prospecspecialties.com
Web: prospecspecialties.com

CAC04 SYSTEM

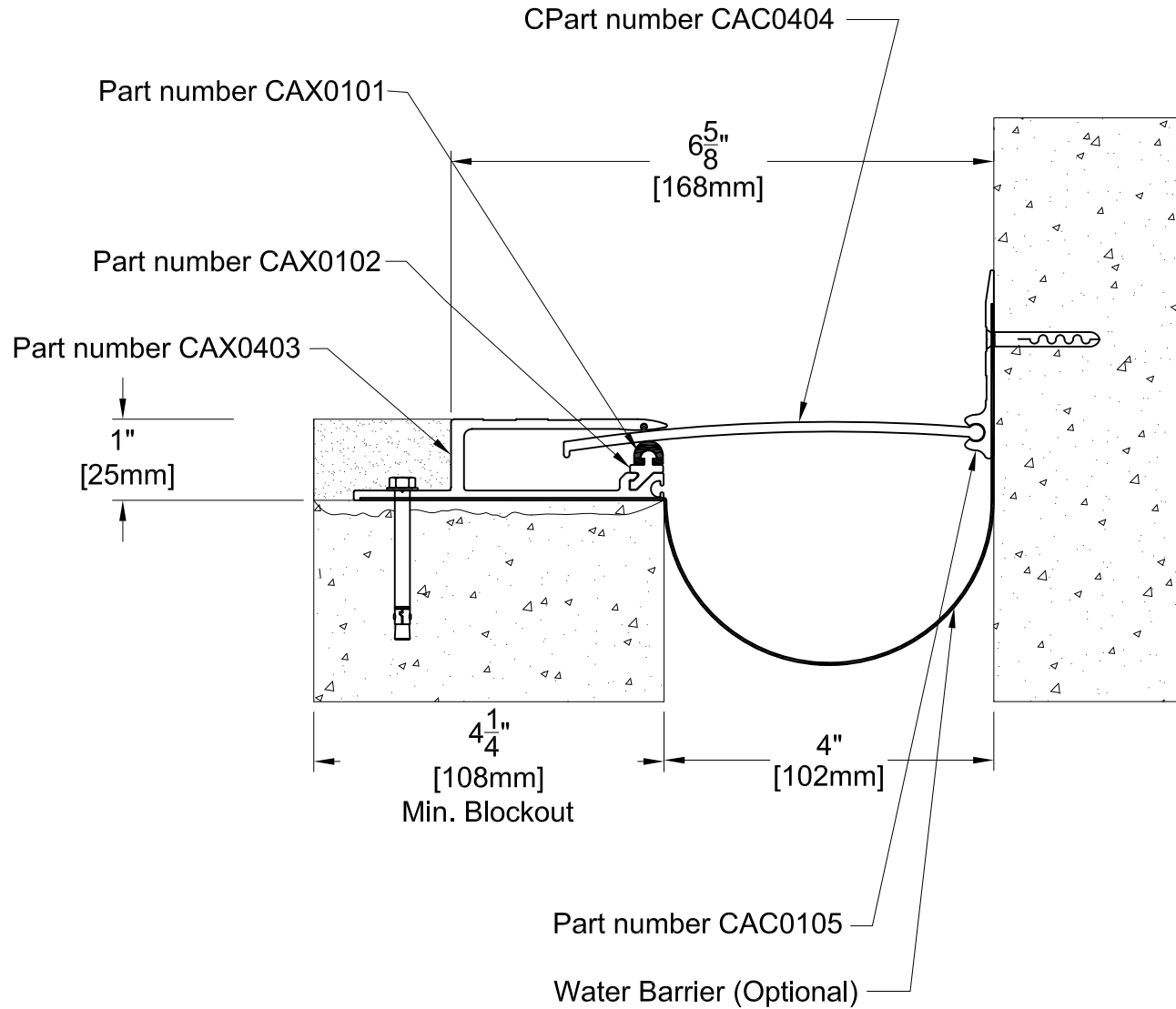

TECHNICAL DATA	IMPERIAL (Inc)	METRIC (mm)
Joint Width	4"	100
Movement ± (Horizontal)	1"	25
Movement ± (Vertical)	1/2"	13
Load	1 (Ton)	
Date: Jan., 2012	Scale: NTS	
Rev:	Drawn by :	

APPLICATION:
EXPANSION JOINT COVER FOR FLOOR TO WALL



PROSPEC SPECIALTIES INC.
3601 HIGHWAY 7, SUITE 400
MARKHAM ON L3R 0M3, CANADA.
TEL: (888) - 749 - 8456,
FAX: (888) - 749 - 8455
Email: info@prospecspecialties.com
Web: prospecspecialties.com

CAC06 SYSTEM

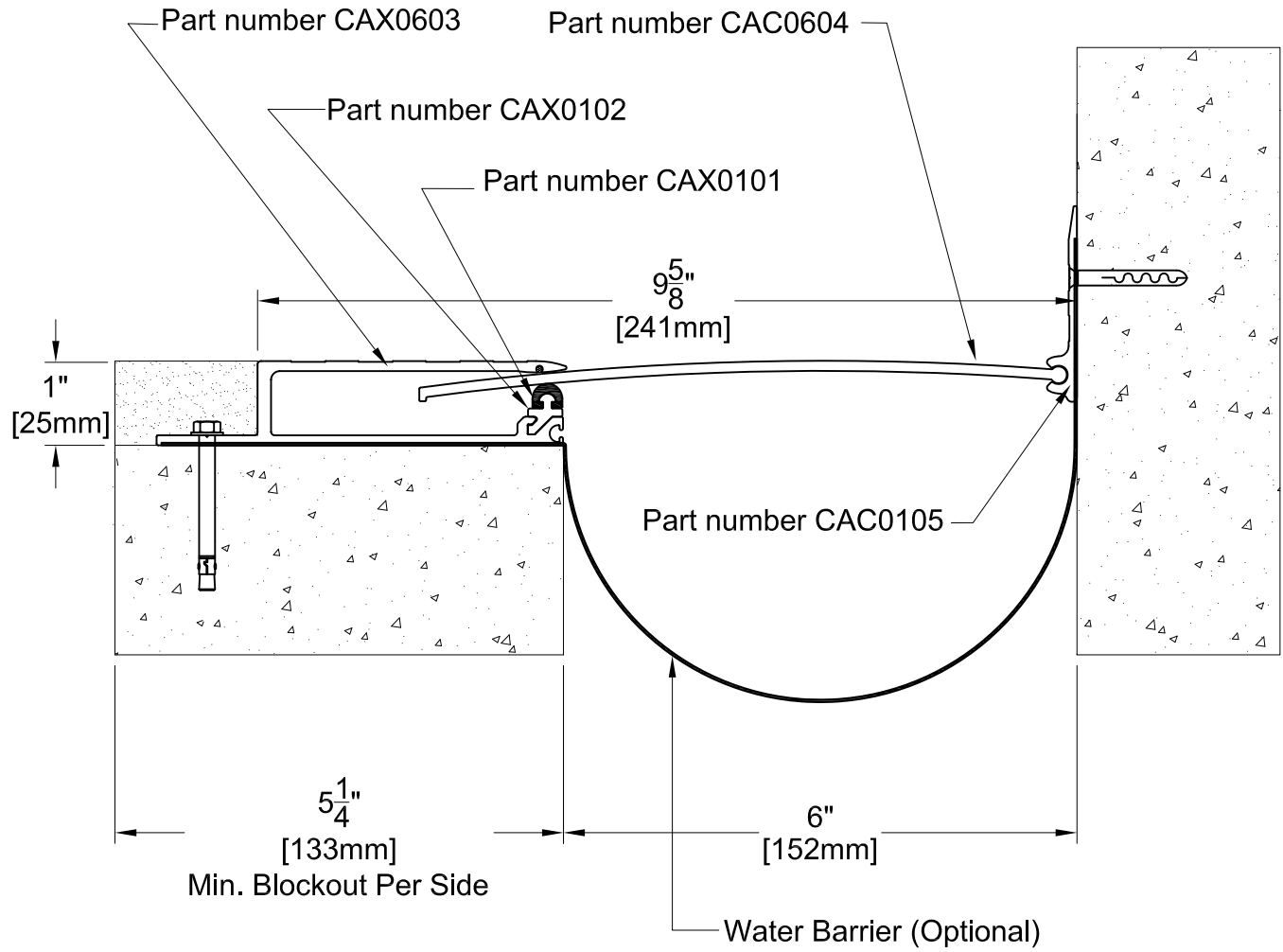

TECHNICAL DATA	IMPERIAL (inc)	METRIC (mm)
Joint Width	6"	152
Movement ± (Horizontal)	3/2"	38
Movement ± (Vertical)	3/4"	19
Load	1 (Ton)	
Date: Jan., 2012	Scale: NTS	
Rev:	Drawn by :	

APPLICATION:
EXPANSION JOINT COVER FOR FLOOR TO WALL



PROSPEC SPECIALTIES INC.
3601 HIGHWAY 7, SUITE 400
MARKHAM ON L3R 0M3, CANADA.
TEL: (888) - 749 - 8456,
FAX: (888) - 749 - 8455
Email: info@prospecspecialties.com
Web: prospecspecialties.com