

AKC01 SYSTEM

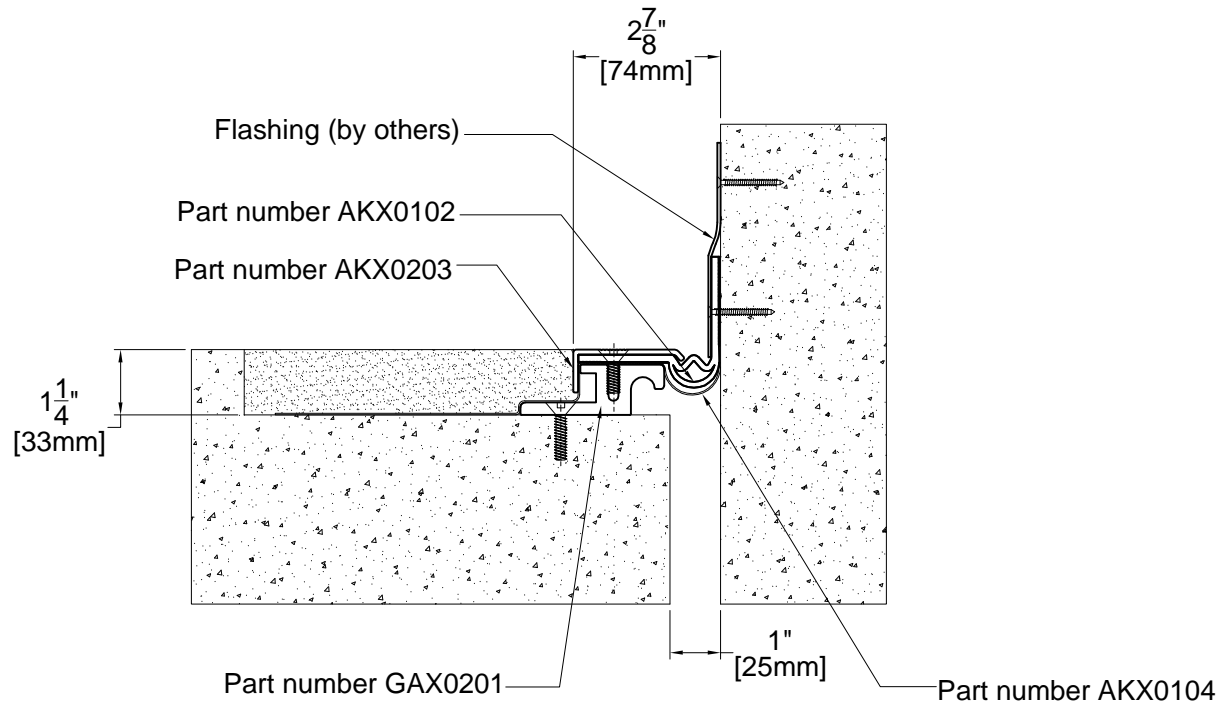

TECHNICAL DATA	IMPERIAL (inc)	METRIC (mm)
Joint Width	1"	26
Movement ± (Horizontal)	1/2"	13
Movement ± (Vertical)	1/2"	13
Load:	5 (Tons)	
Date: Dec., 2013	Scale: NTS	
Rev:	Drawn by : NP	

APPLICATION: Expansion Joint Cover for Floor to Wall Condition (Heavy Duty)



PROSPEC SPECIALTIES INC.
 3601 HIGHWAY 7, SUITE 400
 MARKHAM ON L3R 0M3, CANADA.
 TEL: (888) - 749 - 8456,
 FAX: (888) - 749 - 8455
 Email: info@prospecspecialties.com
 Web: prospecspecialties.com

Disclaimer: As Prospec Specialties' Policy is one of continual technical progress for the improvement of the company's services to its customers, the company reserves the right to modify the Designs of its products without notice.

AKC02 SYSTEM

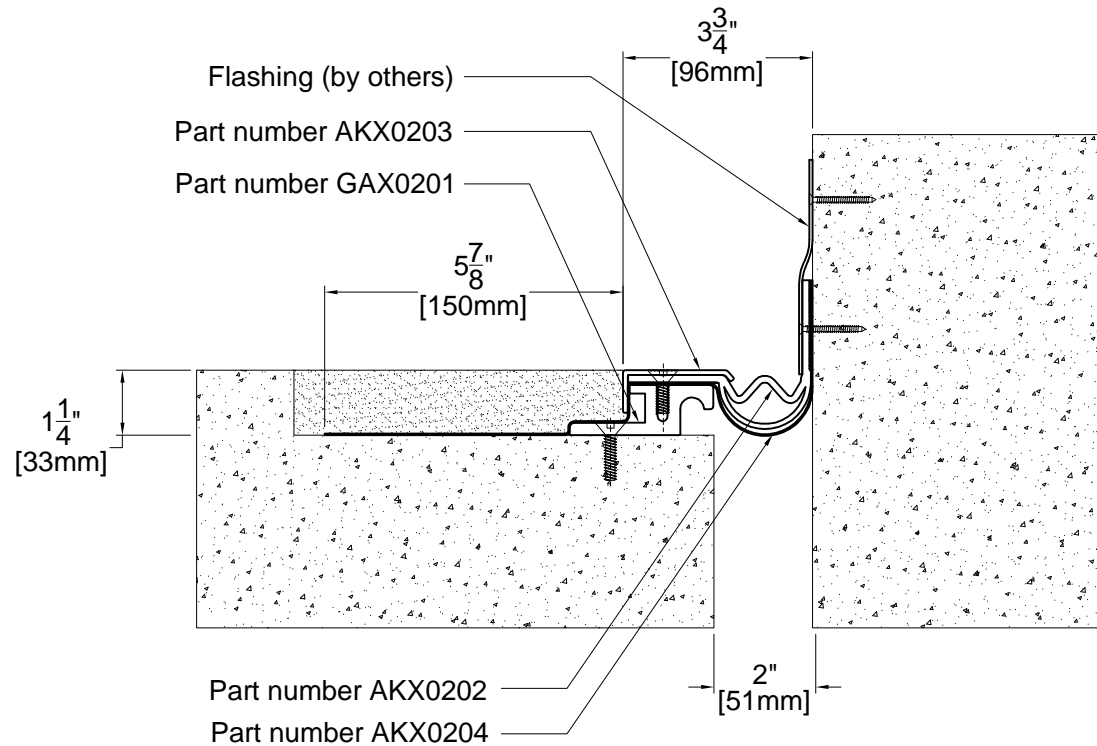

TECHNICAL DATA	IMPERIAL (inc)	METRIC (mm)
Joint Width	2"	51
Movement ± (Horizontal)	1"	25
Movement ± (Vertical)	1"	25
Load:	5 (Tons)	
Date: May., 2013	Scale: Half	
Rev:	Drawn by : NP	

APPLICATION: Expansion Joint Cover for Floor to Wall Condition (Heavy Duty)



PROSPEC SPECIALTIES INC.
 3601 HIGHWAY 7, SUITE 400
 MARKHAM ON L3R 0M3, CANADA.
 TEL: (888) - 749 - 8456,
 FAX: (888) - 749 - 8455
 Email: info@prospecspecialties.com
 Web: prospecspecialties.com

Disclaimer: As Prospec Specialties' Policy is one of continual technical progress for the improvement of the company's services to its customers, the company reserves the right to modify the Designs of its products without notice.

AKC03 SYSTEM

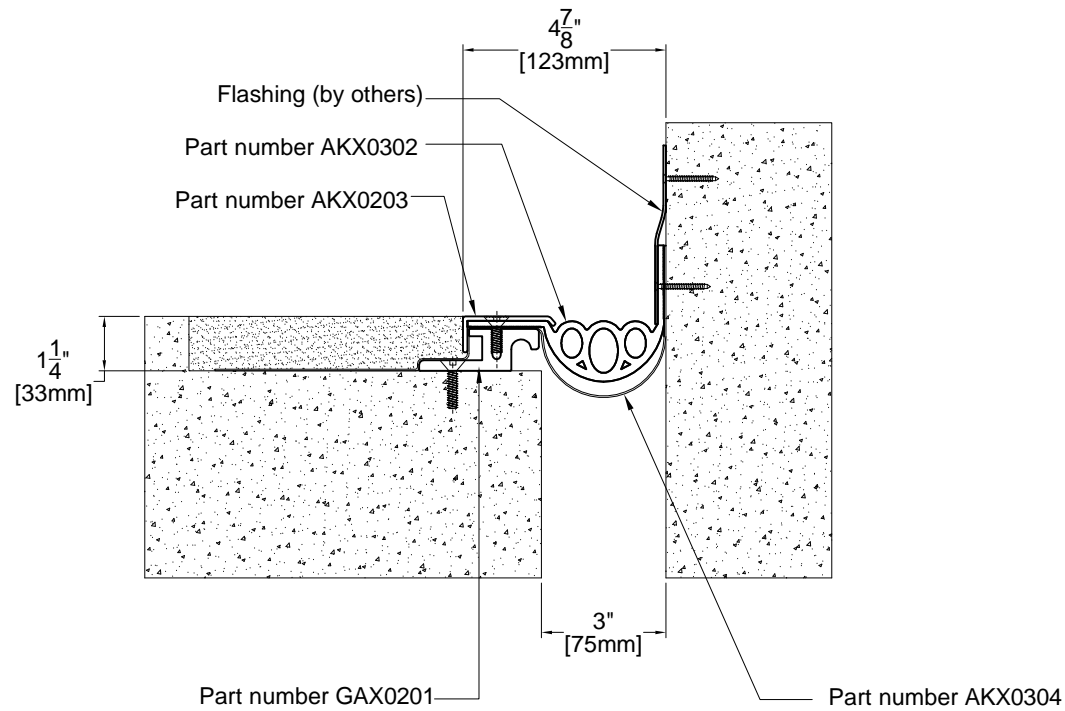

TECHNICAL DATA	IMPERIAL (inc)	METRIC (mm)
Joint Width	3"	76
Movement ± (Horizontal)	1 1/2"	38
Movement ± (Vertical)	1 1/2"	38
Load:	5 (Tons)	
Date: Dec., 2013	Scale: NTS	
Rev:	Drawn by : NP	

APPLICATION: Expansion Joint Cover for Floor to Wall Condition (Heavy Duty)



PROSPEC SPECIALTIES INC.
 3601 HIGHWAY 7, SUITE 400
 MARKHAM ON L3R 0M3, CANADA.
 TEL: (888) - 749 - 8456,
 FAX: (888) - 749 - 8455
 Email: info@prospecspecialties.com
 Web: prospectspecialties.com

Disclaimer: As Prospec Specialties' Policy is one of continual technical progress for the improvement of the company's services to its customers, the company reserves the right to modify the Designs of its products without notice.

AKC04 SYSTEM

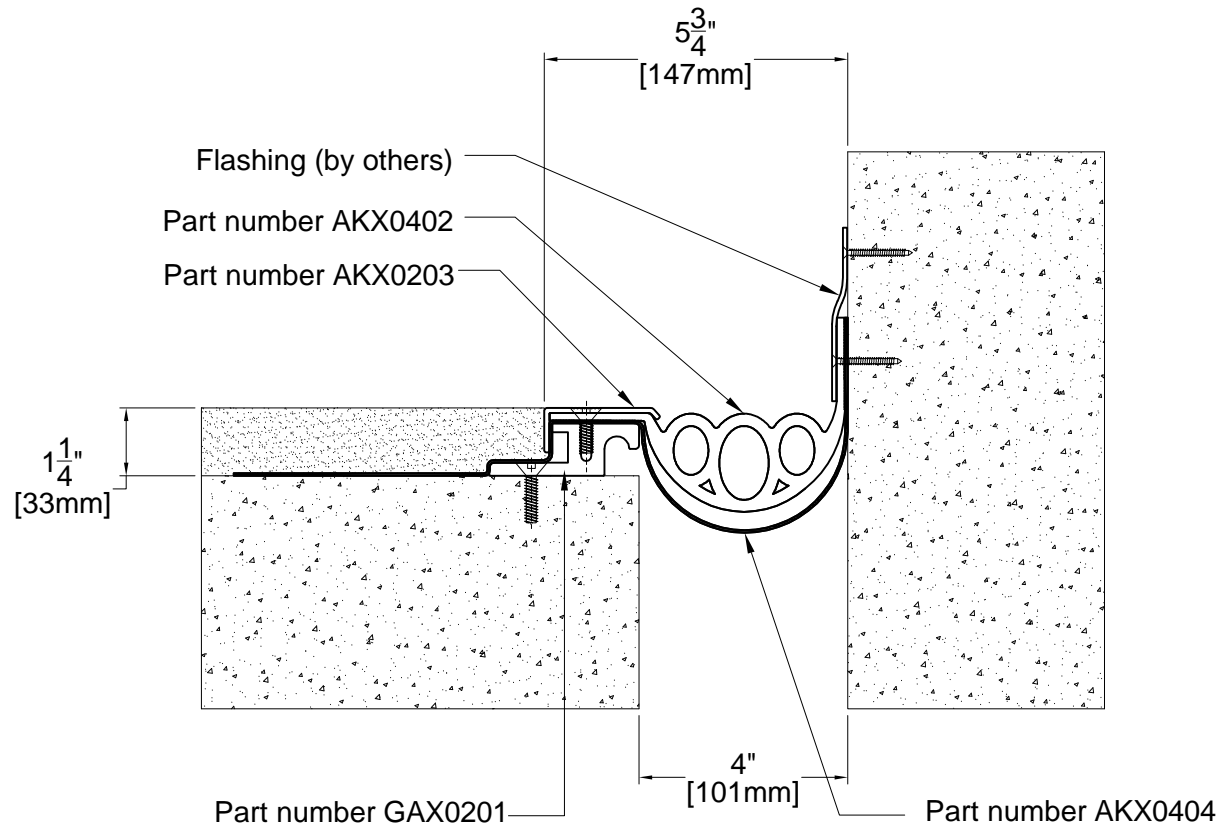

TECHNICAL DATA	IMPERIAL (inc)	METRIC (mm)
Joint Width	4"	102
Movement ± (Horizontal)	2"	51
Movement ± (Vertical)	2"	51
Load:	5 (Tons)	
Date: Dec., 2013	Scale: NTS	
Rev:	Drawn by: NP	

APPLICATION: Expansion Joint Cover for Floor to Wall Condition (Heavy Duty)



PROSPEC SPECIALTIES INC.
 3601 HIGHWAY 7, SUITE 400
 MARKHAM ON L3R 0M3, CANADA.
 TEL: (888) - 749 - 8456,
 FAX: (888) - 749 - 8455
 Email: info@prospecspecialties.com
 Web: prospecspecialties.com

Disclaimer: As Prospec Specialties' Policy is one of continual technical progress for the improvement of the company's services to its customers, the company reserves the right to modify the Designs of its products without notice.