

## Corner Guard CG-2A

Material must be stored & installed in controlled environment.

### Preparation

Prior to the installation of corner guard check and verify the installation location and condition, any defects on surfaces must be repaired. It is important that the surfaces are free of all foreign materials, and must be clean, clear, hard, solid, straight and even before beginning installation of corner guard.

### Installation

Figure 1: Position aluminum retainer against wall, allowing 6/16" (10mm) from the bottom of the aluminum to base for bottom cap and mark each mounting hole of the retainer to the wall. Remove the aluminum retainer and drill marked holes.

Figure 2: Replace the aluminum retainer against wall with #10x1½" self tapping screws through the drilled holes and tighten to secure in place.

Figure 3: Overlap the aluminum retainer with the mounting tabs of the top and bottom caps and attach them into retainer using two screws, #8x1¼" self tapping screws per cap.

Figure 4: Position the vinyl cover on the retainer and adjust the top cap for a tight fit. Starting at the bottom, push cover over the retainer, by pressing over the entire length until the vinyl snaps securely in place.

### Cleaning

After the completion of installation, clean the exposed surfaces with non-solvent cleaner.

Fig. 1

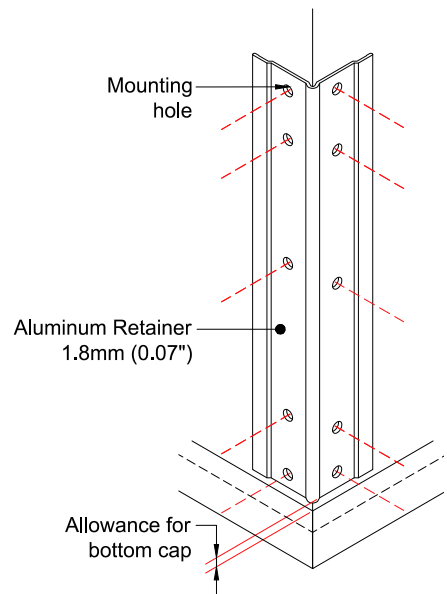

Fig. 2

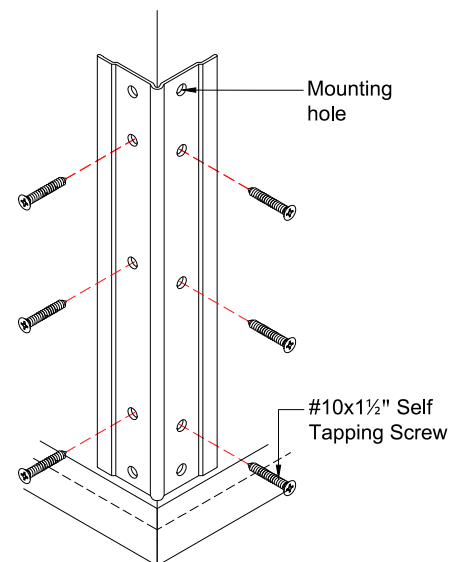

Fig. 3

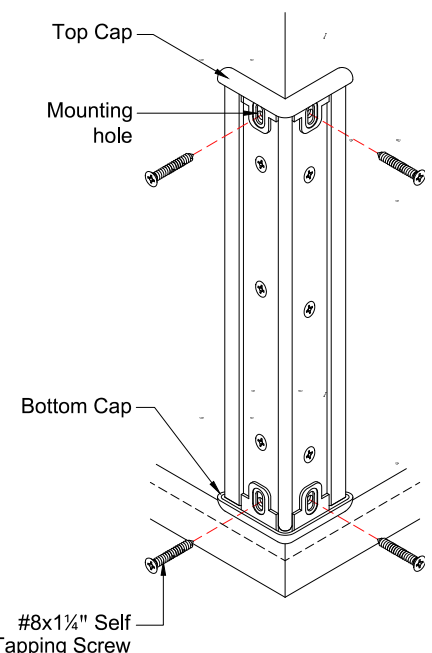

Fig.4

