

## HR-6B Hand Rail

Material must be stored & installed in controlled environment.

1. Prior to the installation of handrail, check and verify the installation location condition and make sure all finishes operations on wall surface is completed including painting and must be clean, clear, hard, solid, straight and even to provide an appropriate surface for installation of hand rail.

Figure 1

2. Cut aluminum retainers to the required length, leaving allowance for left, right, outside and inside corners end caps.

Figure 2

3. Drill holes at the groove line of the aluminum retainer for end caps and brackets using 1/4" (6mm) drill bit. Drill holes spacing 4" (102mm) from each end and maximum of 32" (813mm) centers to center for brackets.

Figure 3

4. Position aluminum retainer against wall at desired height allowing for end and corner caps. Level and mark holes on wall. Remove the retainer and drill marked holes using drill bit.

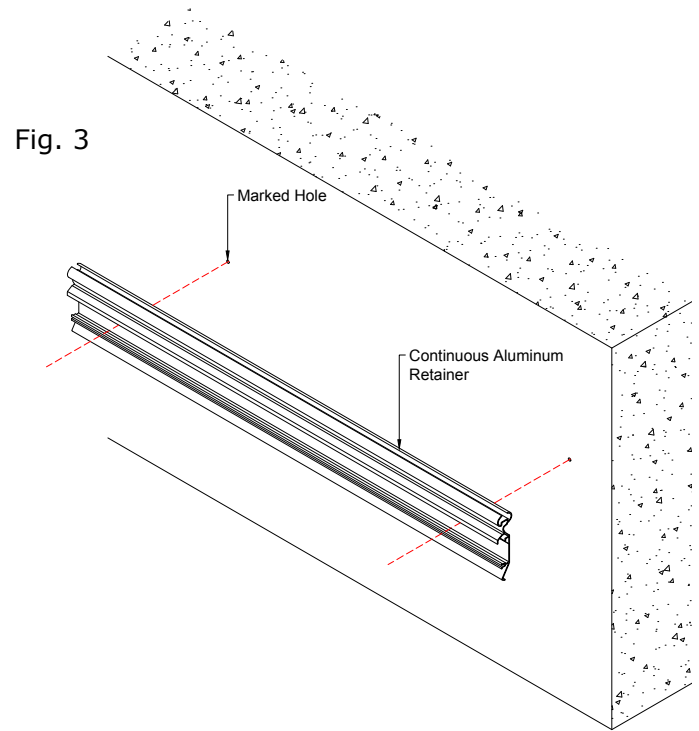
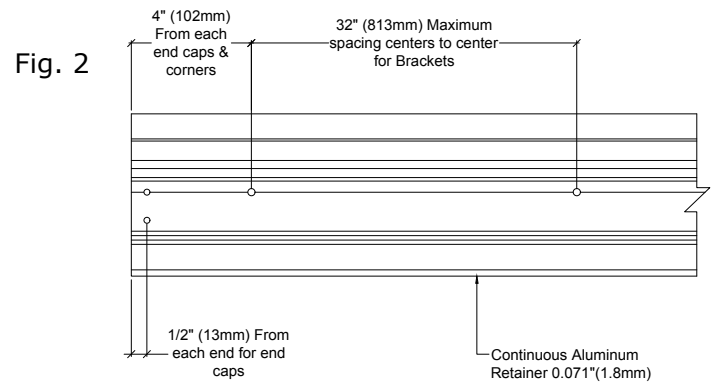
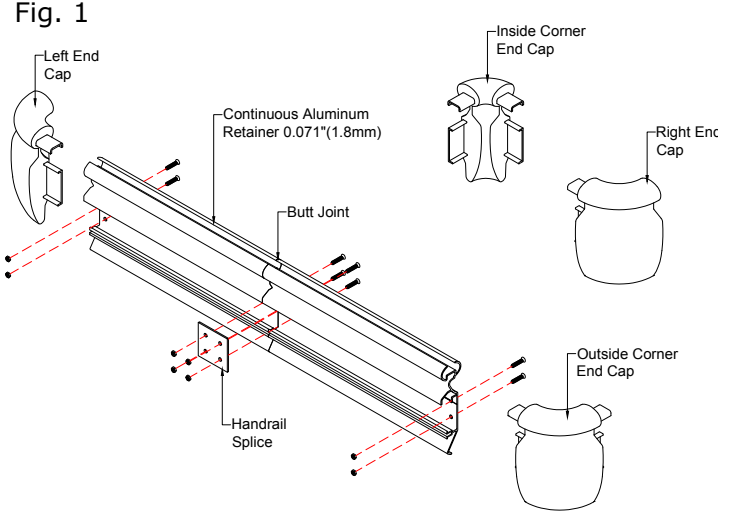

## HR-6B Hand Rail

Figure 4

5. Cut the vinyl covers with the required length. The cover length is determined by measuring the distance between the installed end caps and/or inside/outside corner assemblies. NOTE: Trim all factory edges square before installation.

6. Insert the vinyl covers at the gripping part of the aluminum retainer before assembling the left, right, outside and inside corner caps to aluminum retainer leaving a 1/16" (1.5mm) gap between end caps and retainer to allow for adjustment. loosely attach brackets with the hex head concrete screw to aluminum retainers. Mount on wall, level and tighten screws to secure in place.

Figure 5

7. Cut the rubber bumper with required length between the installed end caps and/or inside corner assemblies. Position and push rubber in place.

8. Position and insert the vinyl cover on the lower gripping part of the aluminum retainer then pivots over the bottom of the retainer for proper tight fit of the cover in place.

9. After the completion of installation, clean the exposed surfaces with non-solvent cleaner.

Fig. 4

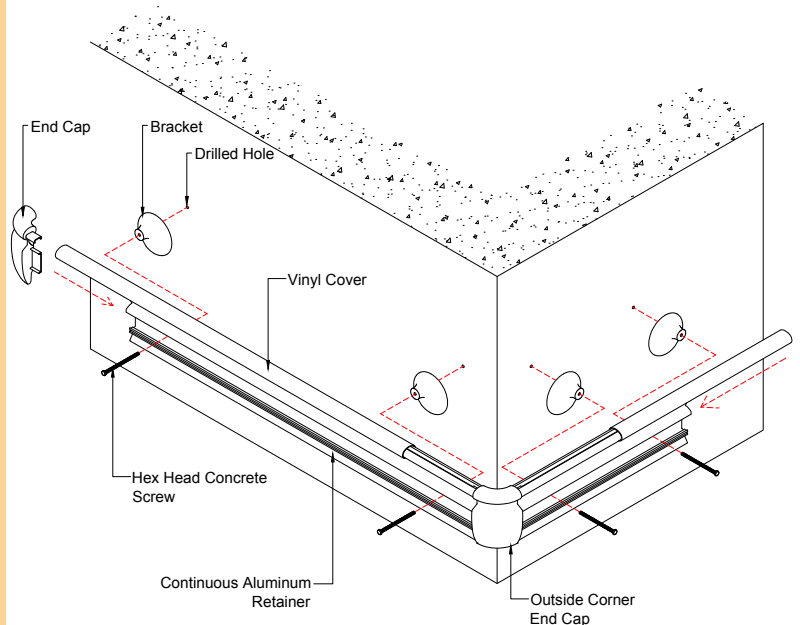

Fig. 5

